

Henderson Bumper Strips

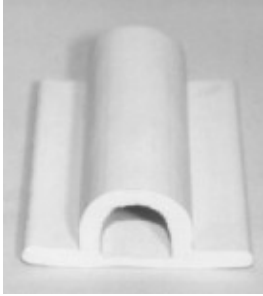

309 HENDERSON FLAT D-SHAPE BUMPER STRIP ITEM NO. 03-09

Material: Designed and extruded from marine-grade vinyl, resistant to yellowing. Meets commercial standard CS230-60.

Weight: 1.13 pounds per foot. **Dimensions:** 1 1/2" x 3 1/2"

Packaging: 6 pieces of 8-foot lengths per shipping carton, 48 feet total.

Application: On wood structures, nail with large-headed aluminum or stainless steel nails, 4 inches on center of top and bottom flanges. On metal structures, use stainless steel or aluminum sheet metal screws and washers.

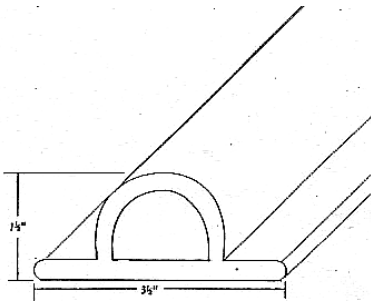

3000 HENDERSON HEAVY DUTY UTILITY FENDER ITEM NO. 03-05

Material: Designed and extruded from marine-grade vinyl, resistant to yellowing. Meets commercial standard CS230-60.

Weight: 2.60 pounds per foot. **Thickness:** 2 1/2" x 5"

Packaging: 3 pieces of 8-foot lengths per shipping carton, 24 feet total.

Application: On wood structures, nail with large-headed aluminum or stainless steel nails, 4 inches on center of top and bottom flanges. On metal structures, use stainless steel or aluminum sheet metal screws and washers.

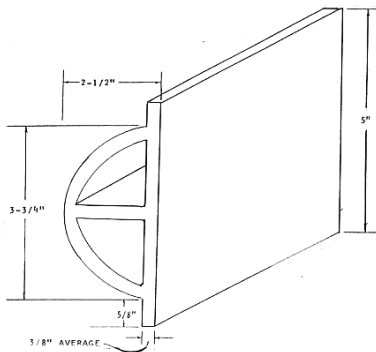
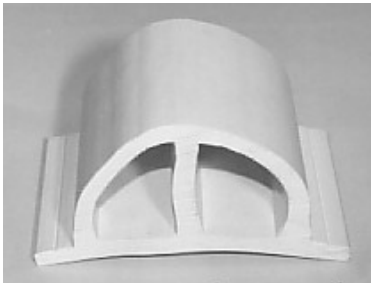

For orders less than full cases, a 25% "split case" charge will apply.



HENDERSON MARINE SUPPLY, INC.
800-523-1586 www.hendersonmarine.com
Specifications subject to change without notice. Not responsible for rust.

Page 03-4
Last Updated: 1/28/2003 9:02:00 AM