

Henderson Bumper Strips

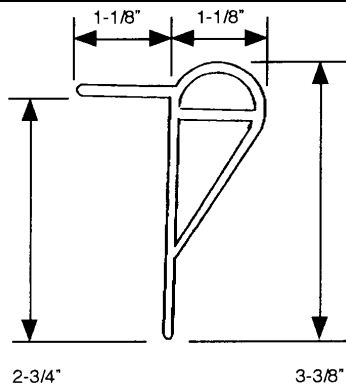
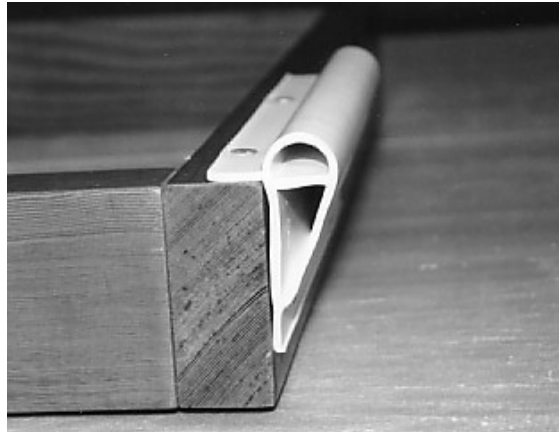

302 HENDERSON HEAVY WEIGHT BUMPER STRIP ITEM NO. 03-02

Material: Designed and extruded from marine-grade vinyl, resistant to yellowing. Meets commercial standard CS230-60.

Weight: 0.85 pounds per foot. **Average Wall Thickness:** 5/32"

Packaging: 12 pieces of 8-foot lengths per shipping carton, 96 feet total.

Application: On wood structures, nail with large-headed aluminum or stainless steel nails, 4 inches on center of top and bottom flanges. On metal structures, use stainless steel or aluminum sheet metal screws and washers.

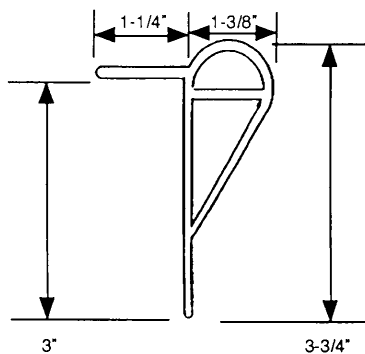

310 HENDERSON EXTRA WEIGHT BUMPER STRIP ITEM NO. 03-10

Material: Designed and extruded from marine-grade vinyl, resistant to yellowing. Meets commercial standard CS230-60.

Weight: 1.35 pounds per foot. **Average Wall Thickness:** 5/32"

Packaging: 10 pieces of 8-foot lengths per shipping carton, 80 feet total.

Application: On wood structures, nail with large-headed aluminum or stainless steel nails, 4 inches on center of top and bottom flanges. On metal structures, use stainless steel or aluminum sheet metal screws and washers.

For corner dock protection see catalog page 03-5. For orders less than full cases, a 25% "split case" charge will apply.



HENDERSON MARINE SUPPLY, INC.

Page 03-3
Last Updated: 9/17/2003 5:18:00 PM