

Henderson Bumper Strips

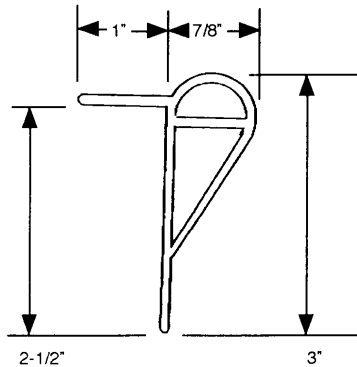

300A HENDERSON LIGHT WEIGHT BUMPER STRIP ITEM NO. 03-00A

Material: Designed and extruded from marine-grade vinyl, resistant to yellowing. Meets commercial standard CS230-60.

Weight: 0.53 pounds per foot. **Average Wall Thickness:** .110"

Packaging: 15 pieces of 8-foot lengths per shipping carton, 120 feet total.

Application: On wood structures, nail with large-headed aluminum or stainless steel nails, 4 inches on center of top and bottom flanges. On metal structures, use stainless steel or aluminum sheet metal screws and washers.

Available only by special order. Minimum order is 2500 L ft.

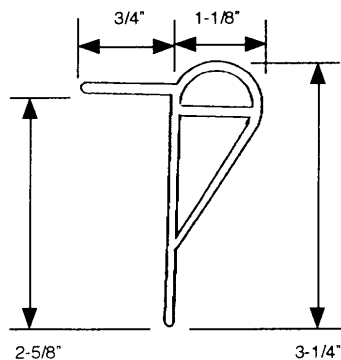

301 HENDERSON STANDARD WEIGHT BUMPER STRIP ITEM NO. 03-01

Material: Designed and extruded from marine-grade vinyl, resistant to yellowing. Meets commercial standard CS230-60.

Weight: 0.625 pounds per foot. **Average Wall Thickness:** 1/8"

Packaging: 12 pieces of 8-foot lengths per shipping carton, 96 feet total.

Application: On wood structures, nail with large-headed aluminum or stainless steel nails, 4 inches on center of top and bottom flanges. On metal structures, use stainless steel or aluminum sheet metal screws and washers.

For corner dock protection see catalog page 03-5. For orders less than full cases, a 25% "split case" charge will apply.

